

CASPAR™

Comprehensive Assessment and Solution Process
For Aging Residents

INTRODUCTION

CASPAR™ consists of 6 sections. The suggested order of completing the protocol is as follows:

1. Contact Information
2. Client Information
3. Problems In the Home
4. Client Goals
5. Description of the Home
6. Summary Information

MATERIALS NEEDED

- CASPAR™
- Camera
- 25' or longer tape measure



1.0

CONTACT INFORMATION

A Client

Name _____

Address _____

Phone _____ Best Time To Phone _____ a.m. _____ p.m.

Fax _____ E-Mail _____

B Additional Contact Person (if necessary)

Name _____

Relationship to Client _____

Phone _____ Best Time To Phone _____ a.m. _____ p.m.

Fax _____ E-Mail _____

C Person Completing CASPAR™

Name _____ ID# _____

Organization (if applicable) _____

Address _____

Phone _____ Best Time To Phone _____ a.m. _____ p.m.

Fax _____ E-Mail _____

D Check Box(es) of Health Care Professionals Working With Client

- Care/Case Manager Occupational Therapist Physical Therapist Social Worker Other _____

E How Did You Find Out About CASPAR™ or Extended Home Living Services?

2.0

CLIENT INFORMATION

A Personal Information

Age _____ (years) Height _____ Weight _____ Gender M _____ F _____

B Client's Medical Diagnoses or Disabilities

Primary medical diagnosis: _____ Year of onset: _____

Other health conditions, physical disabilities, cognitive/intellectual impairments or behavioral issues that affect client's ability to do things in the home. _____

C Mobility Aids Used (check all that apply)

- | | | |
|---|--|--|
| <input type="checkbox"/> Cane(s) Type _____ | <input type="checkbox"/> Crutch(es) Type _____ | <input type="checkbox"/> Walker Type _____ |
| <input type="checkbox"/> Scooter | <input type="checkbox"/> Manual Wheelchair | Width _____ |
| Widest Width _____ | Widest Width _____ | <input type="checkbox"/> Power Wheelchair |
| Max. Length _____ | Max. Length _____ | Widest Width _____ |
| Seat Height _____ | Seat Height _____ | Max. Length _____ |
| | | Seat Height _____ |

D Functional Movement Abilities

Step 1. Check the box corresponding to the **client's rating** of difficulty when the following tasks are done without personal assistance.

Step 2. List any **mobility aid(s)** checked in item C above that is (are) used when doing each task.

Step 3. Provide any **additional comments** that further describe how each task is completed.

Tasks	Step 1: Client's Rating				Step 2: Mobility Aids Used	Step 3: Comments
	Cannot or Do Not Do	Very Difficult	Difficult	Not Difficult		
Turn on light a switch.	0	1	2	3		
Push a button.	0	1	2	3		
Open a drawer.	0	1	2	3		
Turn a doorknob.	0	1	2	3		
Sit upright in a chair.	0	1	2	3		
Transfer from a chair to wheelchair.	0	1	2	3		
Get up from chair and stand.	0	1	2	3		
Walk five feet.	0	1	2	3		
Walk across a room.	0	1	2	3		
Step up on a curb.	0	1	2	3		
Walk up three steps.	0	1	2	3		
Walk up 10 steps or more.	0	1	2	3		
Roll/propel wheelchair 5ft.	0	1	2	3		
Roll/propel wheelchair across a room	0	1	2	3		

3.0

PROBLEMS IN THE HOME

If possible, have the client answer all of the questions in each of the problem areas (Sections 3.1--3.7) below. If not possible, have a family member/caregiver complete the questions.

Step 1. Check the box labeled **problem**, if the task is a problem for the client to do alone or if the task cannot be done.

Step 2. Check the box labeled **help**, if someone helps the client complete the task.

Step 3. List the type of mobility aid(s) and assistive **devices** used in completing the task.

Step 4. Provide any **comments** that will further describe the client's problem(s).

3.1 Getting in and out of the house

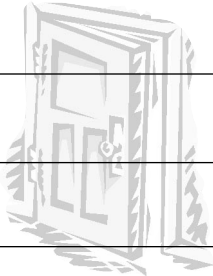
Tasks	Problem	Help	Device	Comments
Getting to any entrance from the street, driveway or sidewalk.	<input type="checkbox"/>	<input type="checkbox"/>		
Going up/down stairs to any entry door.	<input type="checkbox"/>	<input type="checkbox"/>		
Maneuvering into position to open any entry door.	<input type="checkbox"/>	<input type="checkbox"/>		
Locking/unlocking and opening/closing any entry door.	<input type="checkbox"/>	<input type="checkbox"/>		
Going over a threshold at and through any entry door.	<input type="checkbox"/>	<input type="checkbox"/>		
Other (specify):	<input type="checkbox"/>	<input type="checkbox"/>		
	<input type="checkbox"/>	<input type="checkbox"/>		

3.2 Going up and down interior stairs

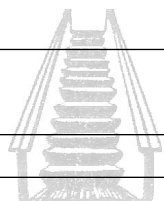
Tasks	Problem	Help	Device	Comments
Going up/down any level change of 1-2 steps.	<input type="checkbox"/>	<input type="checkbox"/>		
Going up/down any level change of 3 or more steps.	<input type="checkbox"/>	<input type="checkbox"/>		
Other (specify):	<input type="checkbox"/>	<input type="checkbox"/>		
	<input type="checkbox"/>	<input type="checkbox"/>		

3.3 Moving around the house



Tasks	Problem	Help	Device	Comments
Maneuvering into position to open/close any interior door.	<input type="checkbox"/>	<input type="checkbox"/>		
Opening/closing any interior door.	<input type="checkbox"/>	<input type="checkbox"/>		
Turning into any room from any hallway or into any hallway from any room.	<input type="checkbox"/>	<input type="checkbox"/>		
Going over a threshold at and through any interior door.	<input type="checkbox"/>	<input type="checkbox"/>		

continue next page

3.3 Moving around the house

Tasks	Problem	Help	Device	Comments
Moving within any hallway or room, or across any floor.	<input type="checkbox"/>	<input type="checkbox"/>		
Other (specify):	<input type="checkbox"/>	<input type="checkbox"/>		
	<input type="checkbox"/>	<input type="checkbox"/>		
	<input type="checkbox"/>	<input type="checkbox"/>		
	<input type="checkbox"/>	<input type="checkbox"/>		

3.4 Using the Bathroom

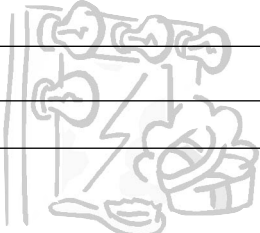
Tasks	Problem	Help	Device	Comments
Toileting				
Getting close enough to any toilet.	<input type="checkbox"/>	<input type="checkbox"/>		
Getting on/off any toilet.	<input type="checkbox"/>	<input type="checkbox"/>		
Reaching the toilet paper at any toilet.	<input type="checkbox"/>	<input type="checkbox"/>		
Flushing any toilet.	<input type="checkbox"/>	<input type="checkbox"/>		
Other (specify):	<input type="checkbox"/>	<input type="checkbox"/>		
	<input type="checkbox"/>	<input type="checkbox"/>		
Bathing/Showering				
Getting close enough to any bathtub/shower.	<input type="checkbox"/>	<input type="checkbox"/>		
Getting in/out of any bathtub/shower.	<input type="checkbox"/>	<input type="checkbox"/>		
Lowering down to/rising up from the bottom of any bathtub.	<input type="checkbox"/>	<input type="checkbox"/>		
Standing while showering in any shower.	<input type="checkbox"/>	<input type="checkbox"/>		
Reaching the faucet and turning the water on/off in any bathtub/shower.	<input type="checkbox"/>	<input type="checkbox"/>		
Reaching the water, soap, shampoo, etc. in any bathtub/shower.	<input type="checkbox"/>	<input type="checkbox"/>		
Other (specify):	<input type="checkbox"/>	<input type="checkbox"/>		
	<input type="checkbox"/>	<input type="checkbox"/>		
Grooming, etc.				
Getting close enough to any bathroom sink.	<input type="checkbox"/>	<input type="checkbox"/>		
Reaching the faucet and turning the water on/off in any bathroom sink.	<input type="checkbox"/>	<input type="checkbox"/>		

continue next page

3.4 Using the Bathroom

Tasks	Problem	Help	Device	Comments
Seeing in the mirror above or near any bathroom sink.	<input type="checkbox"/>	<input type="checkbox"/>		
Getting items from any bathroom cabinet or shelf.	<input type="checkbox"/>	<input type="checkbox"/>		
Other (specify):	<input type="checkbox"/>	<input type="checkbox"/>		
	<input type="checkbox"/>	<input type="checkbox"/>		

3.5 Using the Bedroom

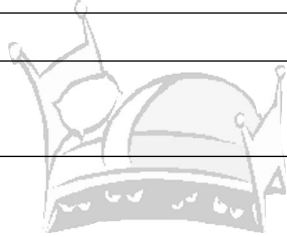
Tasks	Problem	Help	Device	Comments
Getting to any bed.	<input type="checkbox"/>	<input type="checkbox"/>		
Getting in/out of any bed.	<input type="checkbox"/>	<input type="checkbox"/>		
Getting in/out of any chair.	<input type="checkbox"/>	<input type="checkbox"/>		
Getting to any bedroom closet or storage space.	<input type="checkbox"/>	<input type="checkbox"/>		
Reaching items in any bedroom closet or storage space.	<input type="checkbox"/>	<input type="checkbox"/>		
Other (specify):	<input type="checkbox"/>	<input type="checkbox"/>		
	<input type="checkbox"/>	<input type="checkbox"/>		
	<input type="checkbox"/>	<input type="checkbox"/>		
	<input type="checkbox"/>	<input type="checkbox"/>		

3.6 Using the Kitchen

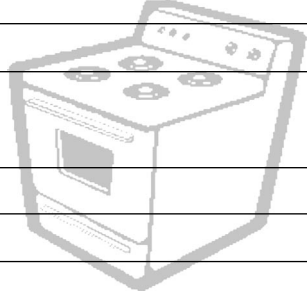
Tasks	Problem	Help	Device	Comments
Getting close enough to any kitchen base cabinet or drawer.	<input type="checkbox"/>	<input type="checkbox"/>		
Using any kitchen base cabinet.	<input type="checkbox"/>	<input type="checkbox"/>		
Using any kitchen drawer.	<input type="checkbox"/>	<input type="checkbox"/>		
Using any kitchen counter and/or workspace.	<input type="checkbox"/>	<input type="checkbox"/>		
Getting close enough to any kitchen sink.	<input type="checkbox"/>	<input type="checkbox"/>		
Reaching the faucet and turning the water on/off in any kitchen sink.	<input type="checkbox"/>	<input type="checkbox"/>		
Getting close enough to any kitchen appliance.	<input type="checkbox"/>	<input type="checkbox"/>		
Using any kitchen appliance.	<input type="checkbox"/>	<input type="checkbox"/>		
Using any kitchen wall cabinet.	<input type="checkbox"/>	<input type="checkbox"/>		
Storing/taking items from any kitchen shelf or closet.	<input type="checkbox"/>	<input type="checkbox"/>		
Other (specify):	<input type="checkbox"/>	<input type="checkbox"/>		
	<input type="checkbox"/>	<input type="checkbox"/>		
	<input type="checkbox"/>	<input type="checkbox"/>		

continue next page

3.7 Doing Laundry

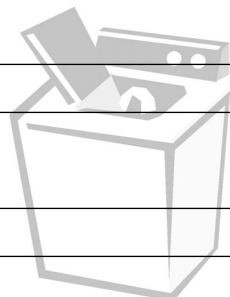
Tasks	Problem	Help	Device	Comments
Getting close enough to any washer, dryer, or storage space.	<input type="checkbox"/>	<input type="checkbox"/>		
Using any washer or dryer.	<input type="checkbox"/>	<input type="checkbox"/>		
Using any cabinet or storage space in laundry area.	<input type="checkbox"/>	<input type="checkbox"/>		
Other (specify):	<input type="checkbox"/>	<input type="checkbox"/>		
	<input type="checkbox"/>	<input type="checkbox"/>		

3.8 Controlling Ambient Conditions

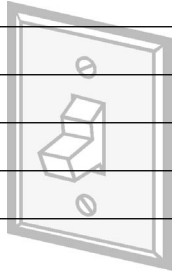
Tasks	Problem	Help	Device	Comments
Locking/unlocking any window.	<input type="checkbox"/>	<input type="checkbox"/>		
Opening/closing any window or window treatment.	<input type="checkbox"/>	<input type="checkbox"/>		
Adjusting light level.	<input type="checkbox"/>	<input type="checkbox"/>		
Plugging/unplugging any electric cord.	<input type="checkbox"/>	<input type="checkbox"/>		
Using any telephone.	<input type="checkbox"/>	<input type="checkbox"/>		
Adjusting any thermostat.	<input type="checkbox"/>	<input type="checkbox"/>		
Using any room heater, fan, or air conditioner.	<input type="checkbox"/>	<input type="checkbox"/>		
Hearing doorbell, smoke alarm, or other auditory cue.	<input type="checkbox"/>	<input type="checkbox"/>		
Other (specify):	<input type="checkbox"/>	<input type="checkbox"/>		
	<input type="checkbox"/>	<input type="checkbox"/>		

3.9 Doing Other Activities

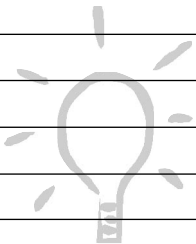
Tasks	Problem	Help	Device	Comments
List other problems in doing things in the home.	<input type="checkbox"/>	<input type="checkbox"/>		
	<input type="checkbox"/>	<input type="checkbox"/>		
	<input type="checkbox"/>	<input type="checkbox"/>		
	<input type="checkbox"/>	<input type="checkbox"/>		
	<input type="checkbox"/>	<input type="checkbox"/>		
	<input type="checkbox"/>	<input type="checkbox"/>		
	<input type="checkbox"/>	<input type="checkbox"/>		
	<input type="checkbox"/>	<input type="checkbox"/>		
	<input type="checkbox"/>	<input type="checkbox"/>		
	<input type="checkbox"/>	<input type="checkbox"/>		

4.0 CLIENT GOALS









4.1 Problems to be Addressed

Step 1. If the client answered yes to any problems within a specific problem area (i.e., 3.1 to 3.7), circle the icon of that problem area in the appropriate column.

Step 2. For each icon selected in Step 1, rate how soon the problems needs to be addressed by circling the appropriate response in the appropriate column.

Step 3. For problem areas that were rated as change soon (3) or change now (4), use **Step 3** to rank order the importance of each, beginning with 1 for the most important.









Step 4. For problem areas that were rated as change soon (3) or change now (4), complete the appropriate section in **Part 5**.

Step 1		Step 2				Step 3
Problem Area		How soon do changes need to be made in each problem area?				Rank In Order Of Importance
		Don't Change At Any Time	Can Wait To Be Changed	Change Soon	Change Now	
	Getting in and out of the house	1	2	3	4	
	Going up and down interior stairs	1	2	3	4	
	Moving around the house	1	2	3	4	
	Using the bathroom	1	2	3	4	
	Using the bedroom	1	2	3	4	
	Using the kitchen	1	2	3	4	
	Doing laundry	1	2	3	4	
	Controlling ambient conditions/using communications	1	2	3	4	
	Doing other activities	1	2	3	4	

4.2 Client Ideas and Concerns









A Problem Areas to be Changed

In the problem areas you want to change soon or now (3 or 4 circled in Step 2 on previous page), do you have any ideas about what changes you would make?

	In and Out	
	Interior Stairs	
	Around the House	
	Bathroom	
	Bedroom	
	Kitchen	
	Laundry	
	Ambient Conditions	
	Other Activities	

B Areas Not Changed

In the problem areas you want to change soon or now (3 or 4 circled in Step 2 on previous page), is there anything that should be left alone and not changed?

	In and Out	
	Interior Stairs	
	Around the House	
	Bathroom	
	Bedroom	
	Kitchen	
	Laundry	
	Ambient Conditions	
	Other Activities	

5.0

DESCRIPTION OF THE HOME

Directions

- Complete only those sections in 5.1 - 5.7 that follow and correspond to problem areas to change soon or change now, as indicated by a 3 or 4 in Section 4.1, Step 2 on page 7.
- To complete Sections 5.1-5.7 you will need to take some measurements and photographs of the house.

Helpful hints:

- ◆ Measurements should be taken to the nearest inch; if less than 1/2 inch, round down.
- ◆ Record measurements in inches or feet and inches, whichever is more comfortable for you.
- ◆ All room measurements should be taken from the wall, not the base board molding at the floor.
- ◆ Measurements from wall to door should be taken from the wall to the inside of the doorframe.
- ◆ Door measurements should be taken by measuring across the door from the right edge to the left edge.

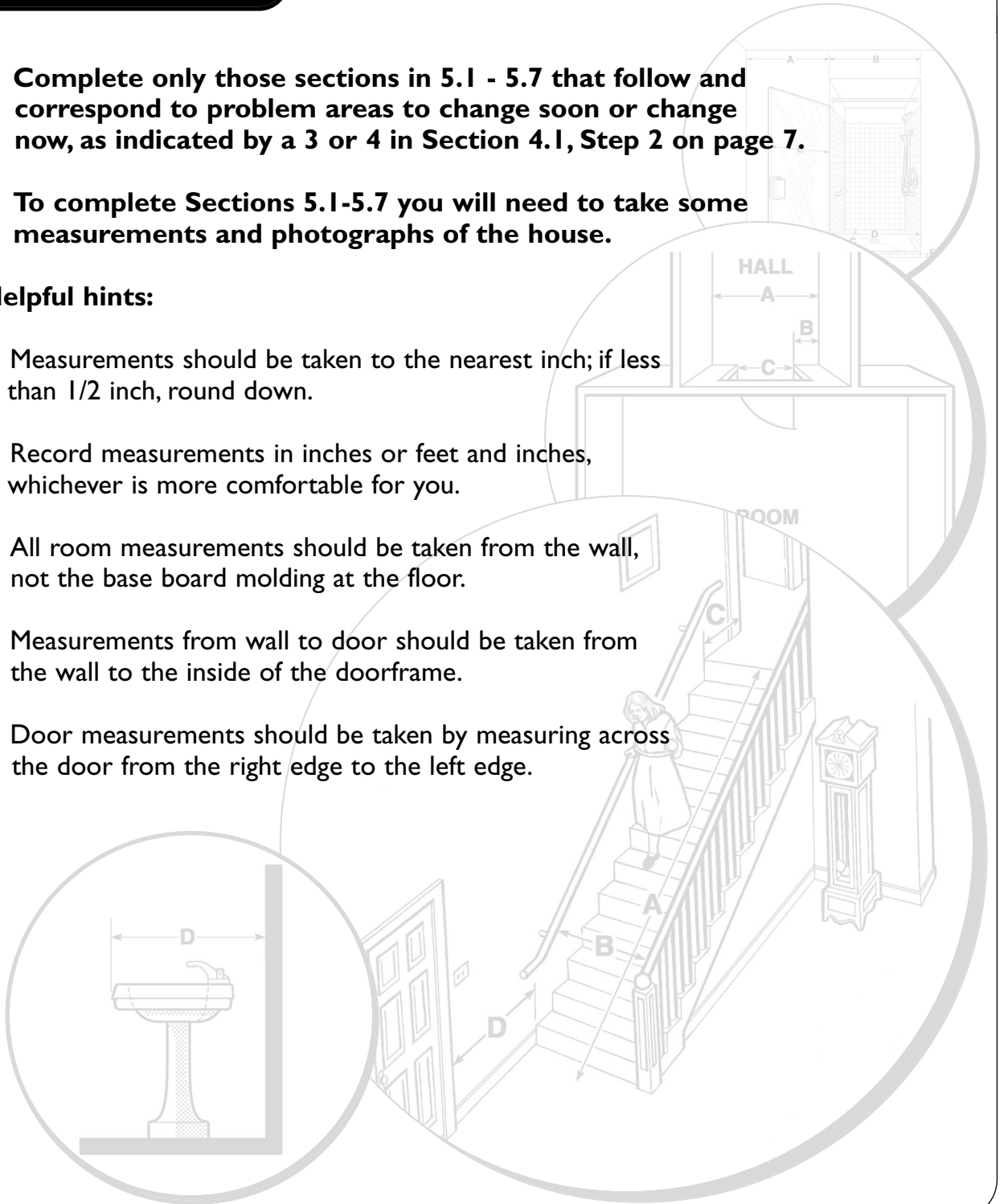

5.1 Getting In and Out of the House

A Photographs of the Outside of the House

Refer to the PHOTO GUIDE in the appendix for recommended location(s) and the required number of photographs needed to document getting in and out of the house.

B Location of Entrances

Directions:

Step 1. Pick the diagram(s) below that most closely match the type(s) of entrances to the home.

Step 2. Check the box next to the location of the entrance or entrances for each diagram picked.

Step 3. Go to the page(s) indicated for each diagram.

Step 4. Provide the measurements for each entrance that corresponds to the diagram.

Step 5. Record the measurements in the appropriate column (i.e., front, back, side, garage, other in the chart below).

One or No Step

- Front
- Back
- Side
- Garage
- Other

Go to Page 11

Steps

- Front
- Back
- Side
- Garage
- Other

Go to Page 11

Steps with Landing

- Front
- Back
- Side
- Garage
- Other

Go to Page 12

Porch

- Front
- Back
- Side
- Garage
- Other

Go to Page 12

C Measurements of Entrances

C-1 One Step or No Step Entrance

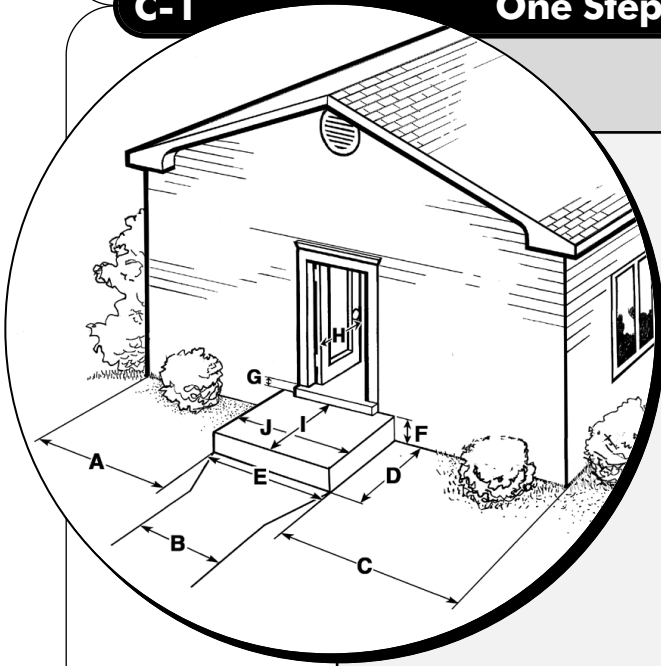

<i>Measurements</i>	<i>Location of Entry</i>				
	Front	Back	Side	Garage	Other
A. Step to Left corner of House					
B. Narrowest Width of Sidewalk					
C. Step to Right Corner of House					
D. House to Outside Edge of Step					
E. Narrowest Width of Step					
F. Vertical Height of Step					
G. Threshold Height					
H. Door Width					
I. Narrowest Depth of Step					
J. Narrowest Length of Landing					

C-2 Entrance with Steps

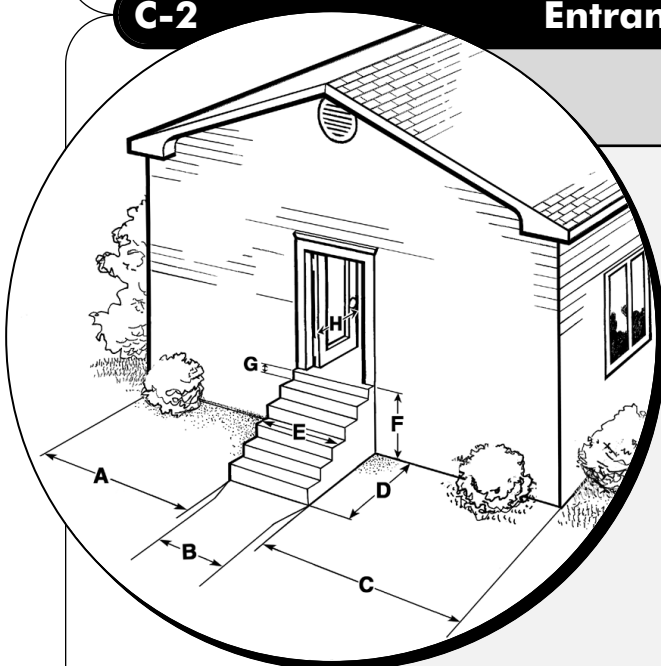

<i>Measurements</i>	<i>Location of Entry</i>				
	Front	Back	Side	Garage	Other
A. Step to Left corner of House					
B. Narrowest Width of Sidewalk					
C. Step to Right Corner of House					
D. House to Outside Edge of Step					
E. Narrowest Width of Step					
F. Vertical Height of Step					
G. Threshold Height					
H. Door Width					

C Measurements of Entrances (continued)

C-3 Steps With a Landing

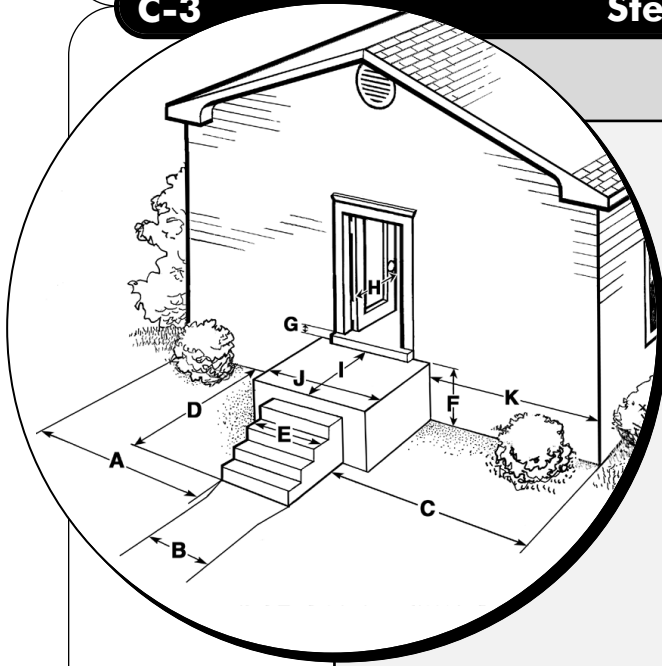

Measurements	Location of Entry				
	Front	Back	Side	Garage	Other
A. Step to Left corner of House					
B. Narrowest Width of Sidewalk					
C. Step to Right Corner of House					
D. House to Outside Edge of Step					
E. Narrowest Width of Step					
F. Vertical Height of Step					
G. Threshold Height					
H. Door Width					
I. Narrowest Depth of Step					
J. Narrowest Length of Landing					
K. Landing at Right Corner of House					

C-4 Entrance With a Porch



Measurements	Location of Entry				
	Front	Back	Side	Garage	Other
A. Step to Left corner of House					
B. Narrowest Width of Sidewalk					
C. Step to Right Corner of House					
D. Porch to Outside Edge of Step					
E. Narrowest Width of Step					
F. Vertical Height of Porch					
G. Threshold Height					
H. Door Width					
I. Narrowest Depth of Porch					
J. Narrowest Length of Porch					
K. Porch to Right Corner of House					

5.2 Going Up and Down Interior Stairs

A Photographs of Interior Stairs

Refer to the PHOTO GUIDE in the appendix for recommended location(s) and the required number of photographs needed to document going up and down interior stairs.

B Location of Interior Stairs

Directions:

Step 1. Assign a number (e.g. Stair 1, stair 2, etc.) to each flight of interior stairs that needs to be changed soon or now

Step 2. Put an (x) in the circle to next to the location of each stair in the lists below.

Step 3. Indicate the location of the interior stair(s).

STAIR 1

- Basement to 1st Floor
- 1st to 2nd Floor
- 2nd to 3rd Floor

STAIR 2

- Basement to 1st Floor
- 1st to 2nd Floor
- 2nd to 3rd Floor

STAIR 3

- Basement to 1st Floor
- 1st to 2nd Floor
- 2nd to 3rd Floor

STAIR 4

- Basement to 1st Floor
- 1st to 2nd Floor
- 2nd to 3rd Floor

C Measurements of Doors, Doorways, and Interior Stairs

Directions:

Step 1. Pick the diagram(s) below that most closely match the type(s) of interior stair that needs to be changed soon or now. For curved stair or others that do not match the diagrams, provide only photographs.

Step 2. Go to the pages indicated for each diagram.

Step 3. Provide the measurements indicated for each stair that corresponds to the diagram.

Step 4. Record the measurements in the appropriate column (i.e., stair 1, 2, 3, 4).

**STRAIGHT
STAIR**
Go to Page 14

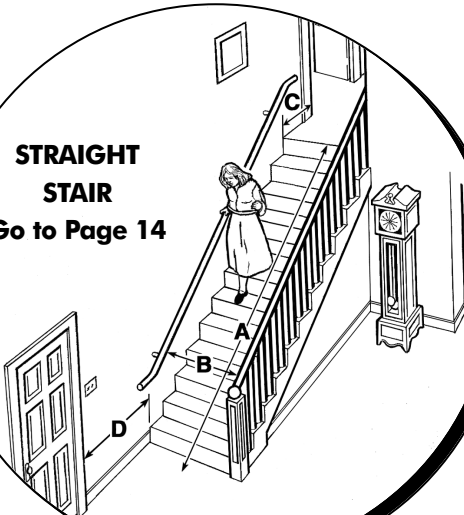

**STAIR with 90
Degree Turns**
Go to Page 14

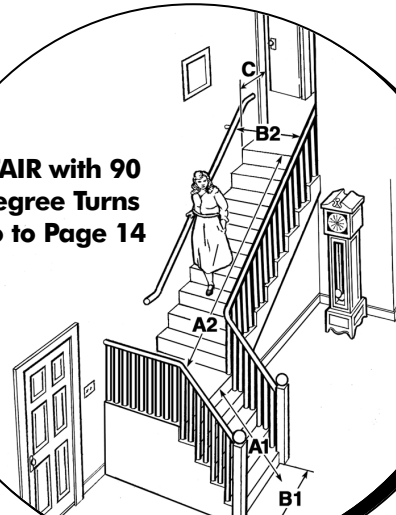

C Measurements of Interior Stairs (continued)

C-1 Straight Stair

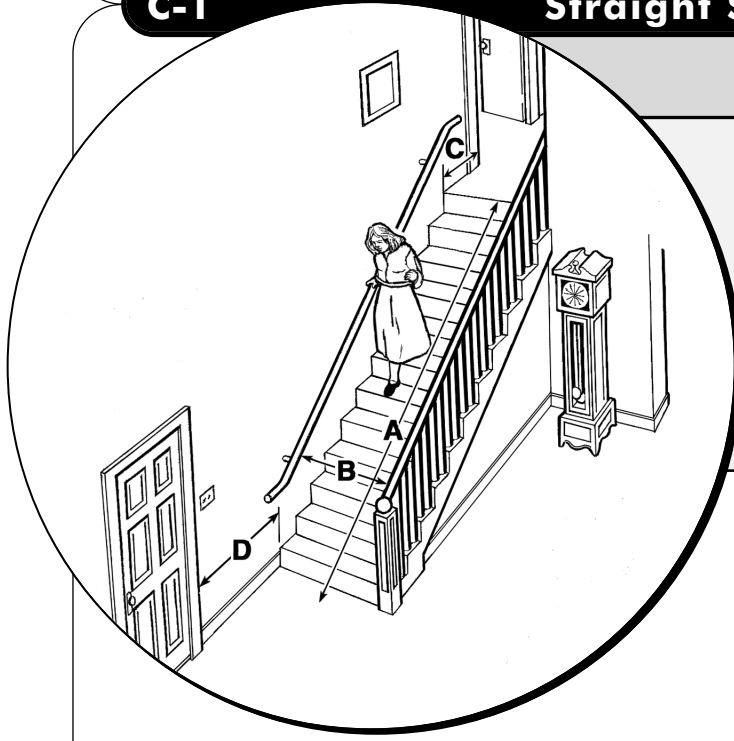

Measurements	Stair 1	Stair 2	Stair 3	Stair 4
A. Length				
B. Width				
C. Top Step to Opening				
D. Bottom Step to Opening				

C-2 Stair With 90 Degree Turns

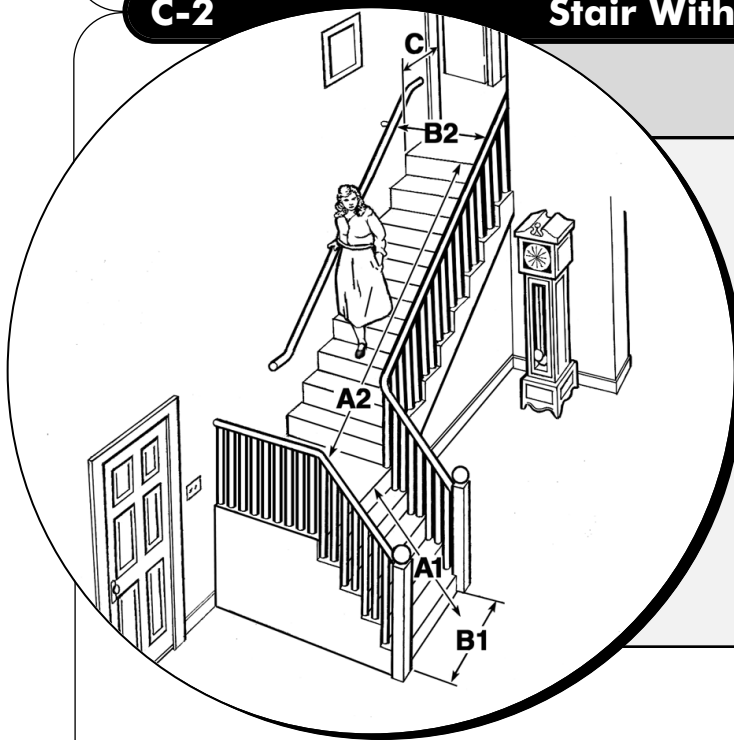

Measurements	Stair 1	Stair 2	Stair 3	Stair 4
A1. Bottom Length				
A2. Top Length				
B1. Bottom Width				
B2. Top Width				
C. Top Step to Opening				
D. Bottom Step to Opening				

5.3 Moving Around the House

A Photographs of Doors, Doorways, and Halls

Refer to the PHOTO GUIDE in the appendix for recommended location(s) and the required number of photographs needed to document problems related to moving around the house.

B Location of Doors, Doorways, and Halls

Directions:

Step 1. In Column 1 of the table below, list the specific doors and doorways that need to be changed soon or now and indicate the floor on which they are located.

Step 2. In Column 2, list the specific hallways that need to be changed soon or now and indicate the floor on which they are located.

Column 1. Doors & Doorways

Name	Floor
1	
2	
3	
4	
5	

Column 2. Intersecting Halls

Name	Floor
1	
2	
3	
4	
5	

C Measurements of Doors, Doorways, and Halls

Directions:

Step 1. Pick the diagram(s) below that most closely match the door(s), doorway(s), and hall(s) that need to be changed soon or now.

Step 2. Go to the page indicated for each diagram.

Step 3. Provide the measurements indicated on the diagram.

Step 4. Record the measurements for each door, doorway, or hall in the numbered column corresponding to the numbered row in Step 2, above.

Room Along Hall

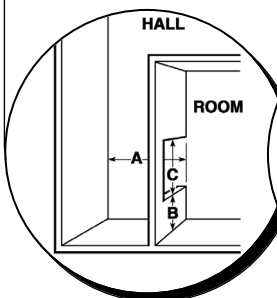

Room At End of Hall

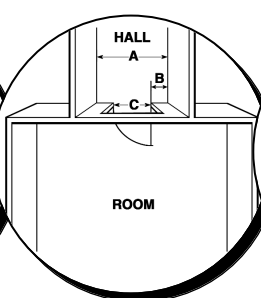

Room to Room

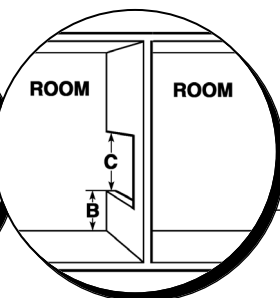

"L"-Shaped Hall

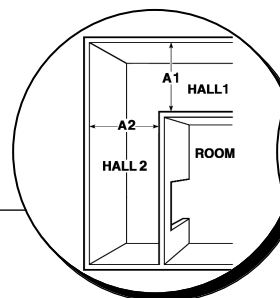

"T" or "+" Hall Intersection

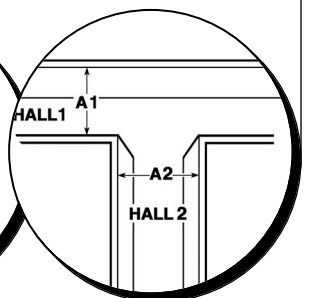

Doors & Doorways (Go to Page 16)

Intersecting Halls (Go to Page 16)

C Measurements of Entrances Doors, Doorways, and Halls (continued)

C-1 Doors and Doorways

Measurements	Door or Doorway # (from Step 3)				
	1	2	3	4	5
A. Hallway Width					
B. Door to Closet Wall					
C. Door(way) Width					

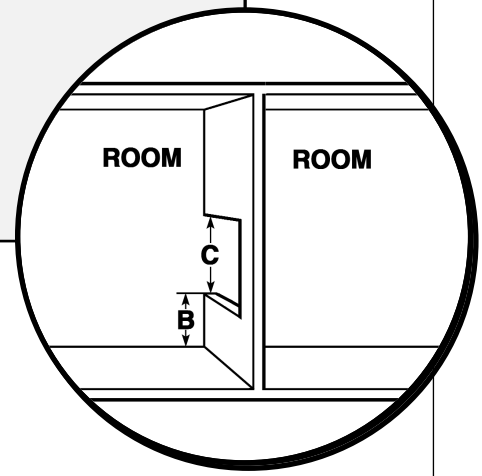
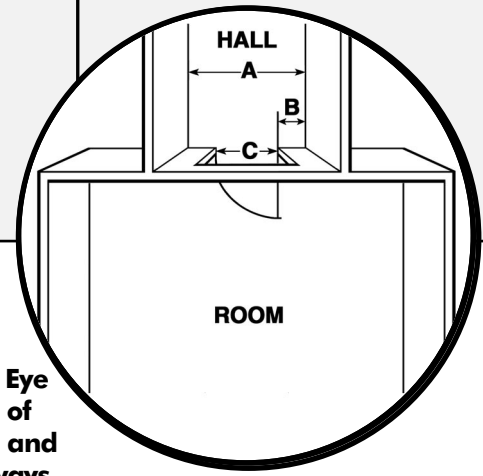
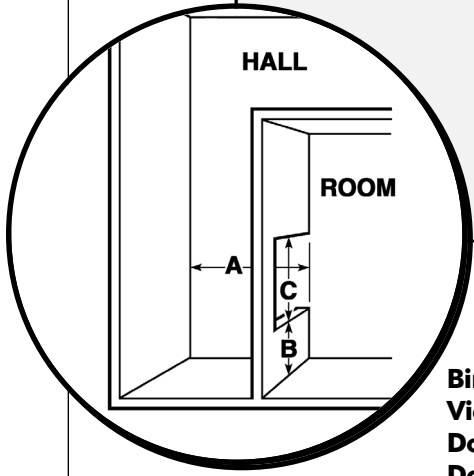

Bird's Eye Views of Doors and Doorways

C-2 Intersecting Halls

Measurements	Hallway # (from Step 3)				
	1	2	3	4	5
A. Hallway Width					
B. Hallway Width					

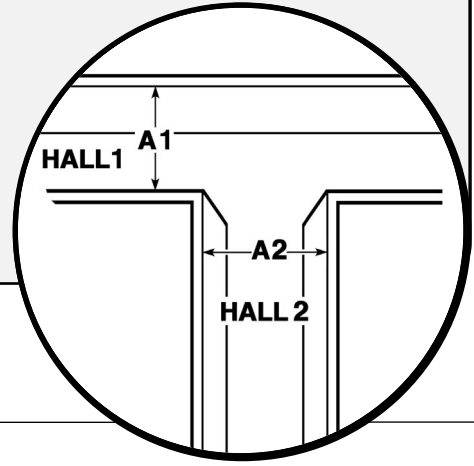
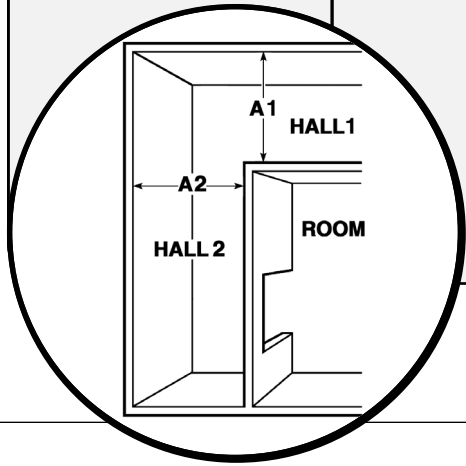

Bird's Eye Views of Intersecting Halls

5.4 Using the Bathroom

A Photographs of Bathrooms

Refer to the PHOTO GUIDE in the appendix for recommended location(s) and the required number of photographs needed to document the bathroom.

B Location of Bathrooms

Directions:

Step 1. Check the box for the **bathrooms/powder room** (half bath) that need to be changed soon or now.

Step 2. Put an (x) in the circle indicate the **location** of the bathroom.

<input type="checkbox"/> BATHROOM 1	<input type="checkbox"/> BATHROOM 2	<input type="checkbox"/> BATHROOM 3	<input type="checkbox"/> POWDER ROOM
<input type="radio"/> Basement	<input type="radio"/> Basement	<input type="radio"/> Basement	<input type="radio"/> Basement
<input type="radio"/> 1st Floor	<input type="radio"/> 1st Floor	<input type="radio"/> 1st Floor	<input type="radio"/> 1st Floor
<input type="radio"/> 2nd Floor	<input type="radio"/> 2nd Floor	<input type="radio"/> 2nd Floor	<input type="radio"/> 2nd Floor
<input type="radio"/> 3rd Floor	<input type="radio"/> 3rd Floor	<input type="radio"/> 3rd Floor	<input type="radio"/> 3rd Floor

C Measurements of Bathrooms

Directions:

Step 1. Use the diagram below to **provide the measurements** indicated for each bathroom(s)

Step 2. Record the measurements for the length of the **WALLS** on the appropriate columns in the chart below.

Step 3. Record the measurements for each fixture in the charts on pages 18-19.

Step 4. Put an "X" through the drawing of any fixture on pages 18-19 that is not present in the room.

C-1 Walls

Birds eye view
of bathroom

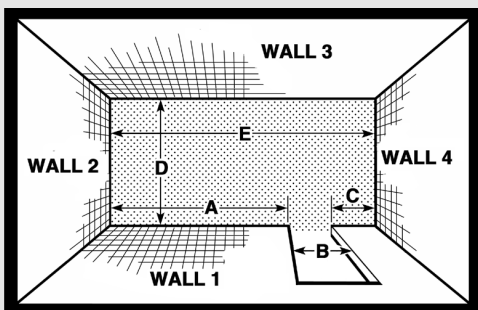

Measurements

- A. Door to Wall 2
- B. Door Width
- C. Door to Wall 4
- D. Wall 1 to Wall 3
- E. Wall 2 to Wall 4

	Bathroom 1	Bathroom 2	Bathroom 3	Powder Room
A. Door to Wall 2				
B. Door Width				
C. Door to Wall 4				
D. Wall 1 to Wall 3				
E. Wall 2 to Wall 4				

continue next page

C Measurements of Bathrooms (continued)

C-2 Fixtures—Toilet

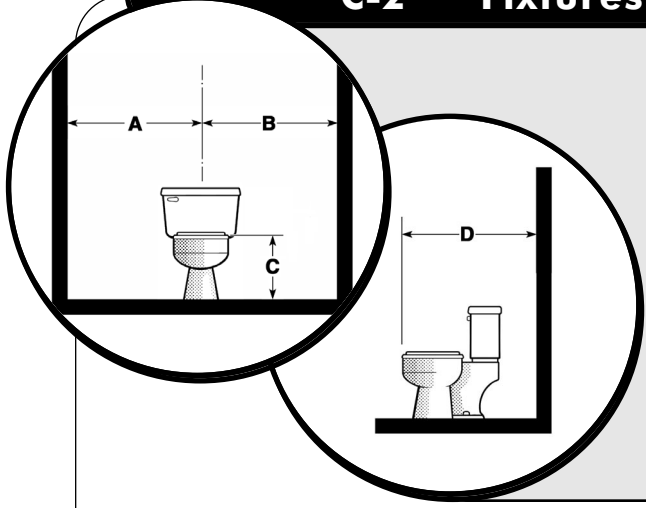

Measurements	Bathroom 1	Bathroom 2	Bathroom 3	Powder Room
Wall Number	# _____	# _____	# _____	# _____
A. Left Wall to Centerline				
B. Right Wall to Centerline				
C. Height of Toilet				
D. Wall Behind Toilet to Front of Toilet				

C-2 Fixtures—Pedestal Sink

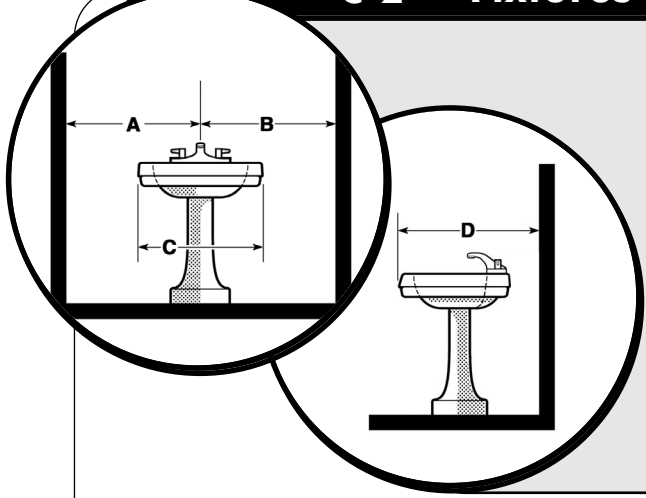

Measurements	Bathroom 1	Bathroom 2	Bathroom 3	Powder Room
Wall Number	# _____	# _____	# _____	# _____
A. Left Wall to Centerline				
B. Right Wall to Centerline				
C. Sink at Widest Point				
D. Wall Behind Sink to Front of Sink				

C-2 Fixtures—Sinks With Base Cabinet

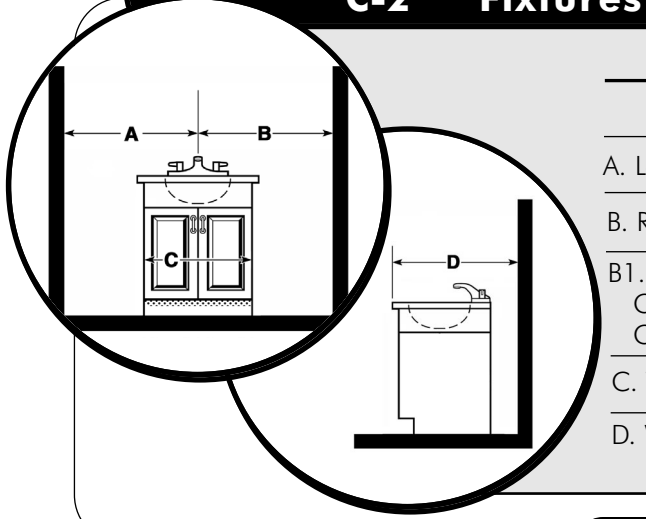

Measurements	Bathroom 1	Bathroom 2	Bathroom 3	Powder Room
Wall Number	# _____	# _____	# _____	# _____
A. Left Wall to Centerline				
B. Right Wall to Centerline				
B1. If Two Sinks, Centerline of Sink 1 to Centerline of Sink 2				
C. Width of Base Cabinet				
D. Wall Behind Sink to Front of Sink				

continue next page

C Measurements of Bathrooms (continued)

C-2 Fixtures—Bathtub or Bathtub With Shower

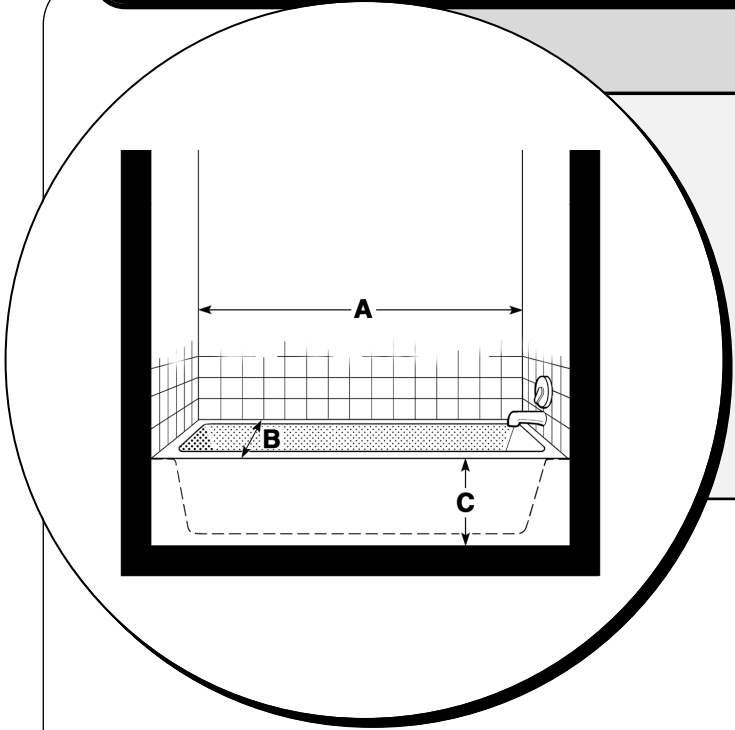

Measurements	Bathroom 1	Bathroom 2	Bathroom 3
Wall Number	# _____	# _____	# _____
A. Length of the Bathtub			
B. Width of the Bathtub			
C. Height of the Bathtub			

C-2 Fixtures—Shower

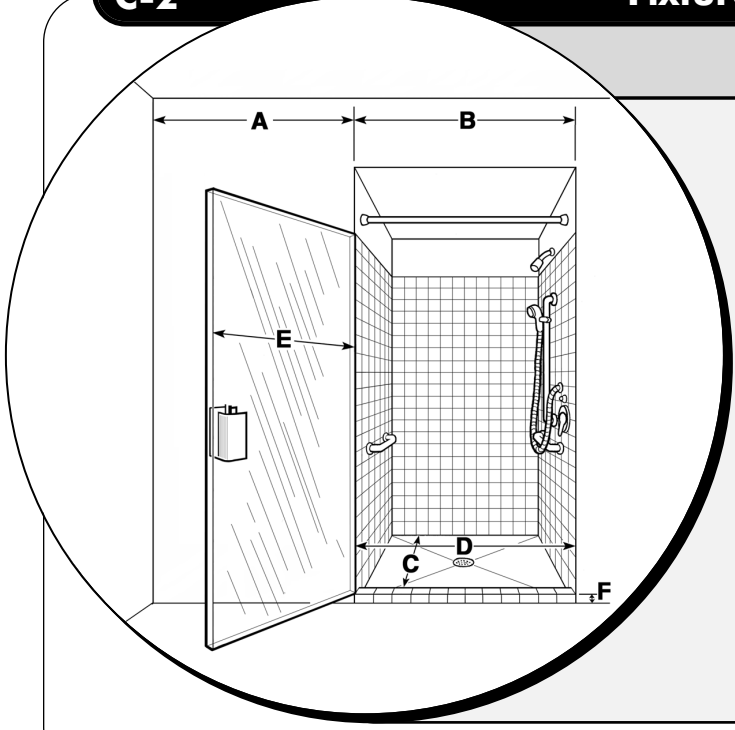

Measurements	Bathroom 1	Bathroom 2	Bathroom 3
Wall Number	# _____	# _____	# _____
A. Left Wall to Outside Edge of Shower			
B. Right Wall to Outside Edge of Shower			
C. Width of Shower			
D. Length of Shower			
E. Width of Shower Door			
F. Height of Curb			

5.5 Using the Bedroom

A Photographs of Bedrooms

Refer to the PHOTO GUIDE in the appendix for recommended location(s) and the required number of photographs needed to document the bedroom.

B Location of Bedrooms

Directions:

Step 1. Check the box for the **bedroom** that need to be changed soon or now.

Step 2. Put an (x) in the circle to indicate the **location** of the bedroom.

BEDROOM 1 (MASTER)

- Basement
- 1st Floor
- 2nd Floor
- 3rd Floor

BEDROOM 2

- Basement
- 1st Floor
- 2nd Floor
- 3rd Floor

BEDROOM 3

- Basement
- 1st Floor
- 2nd Floor
- 3rd Floor

C Measurements of Bedrooms

Directions:

Step 1. Use the diagram below to **provide the measurements** indicated for each bedroom.

Step 2. Record the **measurements** in the appropriate chart.

C-1 Walls

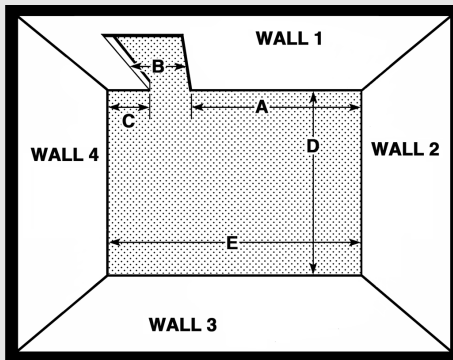

Birds eye view of bedroom

Measurements

	Bedroom 1	Bedroom 2	Bedroom 3	Bedroom 4
A. Door to Wall 2				
B. Door Width				
C. Door to Wall 4				
D. Wall 1 to Wall 3				
E. Wall 2 to Wall 4				

5.6 Using the Kitchen

A Photographs of the Kitchen

Refer to the PHOTO GUIDE in the appendix for recommended location(s) and the required number of photographs needed to document the kitchen.

B Identifying Kitchen Problem Areas

Directions:

Step 1. Put an (x) in the circle beside the **fixture, appliance or cabinet** that needs to be changed soon or now.

FIXTURES

- Sink
- Other _____

APPLIANCES

- Refrigerator
- Stove
- Oven
- Microwave
- Dishwater
- Other _____

CABINETS

- Upper
- Which Ones?

- Lower
- Which Ones?

- Drawers
- Which Ones?

- Pantry
- Other _____

C Measurements of the Kitchen

There are **NO** measurements to be taken at this time.

5.7 Doing Laundry

A Photographs of the Laundry Area

Refer to the PHOTO GUIDE in the appendix for recommended location(s) and the required number of photographs needed to document the laundry area.

B Identifying Laundry Problem Areas

Directions:

Step 1. Put an (x) in the circle beside the **fixture, appliance or cabinet** that needs to be changed soon or now.

FIXTURES

- Sink
- Other _____
- _____
- _____
- _____

APPLIANCES

- Washer
- Dryer
- Other _____
- _____
- _____
- _____

CABINETS

- Upper
- Lower
- Drawers
- Shelves
- Closet
- Other _____
- _____
- _____
- _____

C Measurements of the Laundry Area

Directions:

Step 1. Use the diagram below to **provide the measurements** indicated for the laundry area.

Step 2. Record the measurements in the column marked "length" in the chart.

C-1 Walls

Measurements

Length

A. Door to Wall 2

B. Door Width

C. Door to Wall 4

D. Wall 1 to Wall 3

E. Wall 2 to Wall 4

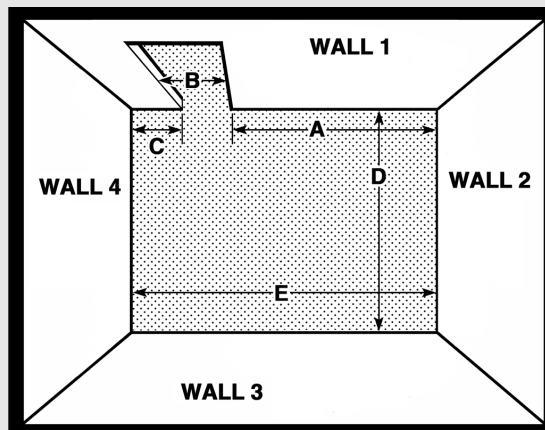

Birds eye view of laundry area

5.8 Controlling Ambient Conditions and Using Communication Devices

A Photographs of Elements for Controlling Ambient Conditions and Communicating

Take a photograph of each specific device associated with problems in Section 3.8 that needs to be changed soon or now.

B Location of Elements

Directions:

Step 1. Check the box for the **building elements** that need to be changed soon or now. Fans, heaters or air conditioners installed in a window or wall of a room should be listed under **room unit**.

Step 2. Indicate the **location** of each element that is checked by using the room designation given in sections 5.1-5.7 (e.g., Bathroom 1) or if the element is in a space not covered in sections 5.1-5.7, write in the name of the space (e.g., Dining Room).

LOCATION:	LIGHT SWITCH	OUTLET	WINDOW	ROOM UNIT	THERMOSTAT
LOCATION 1:	<input type="radio"/> LS 1 _____	<input type="radio"/> Out 1 _____	<input type="radio"/> Win 1 _____	<input type="radio"/> RU 1 _____	<input type="radio"/> Th 1 _____
LOCATION 2:	<input type="radio"/> LS 2 _____	<input type="radio"/> Out 2 _____	<input type="radio"/> Win 2 _____	<input type="radio"/> RU 2 _____	<input type="radio"/> Th 2 _____
LOCATION 3:	<input type="radio"/> LS 3 _____	<input type="radio"/> Out 3 _____	<input type="radio"/> Win 3 _____	<input type="radio"/> RU 3 _____	<input type="radio"/> Th 3 _____
LOCATION 4:	<input type="radio"/> LS 4 _____	<input type="radio"/> Out 4 _____	<input type="radio"/> Win 4 _____	<input type="radio"/> RU 4 _____	
LOCATION 5:	<input type="radio"/> LS 5 _____	<input type="radio"/> Out 5 _____	<input type="radio"/> Win 5 _____	<input type="radio"/> RU 5 _____	

C Measurements of Devices

Directions:

Step 1. Use the diagram below to **provide the measurements** for each element checked in Section B above. **All measurements are to the bottom of the element.**

Step 2. Record the measurements in the for each element.

C-1 Devices

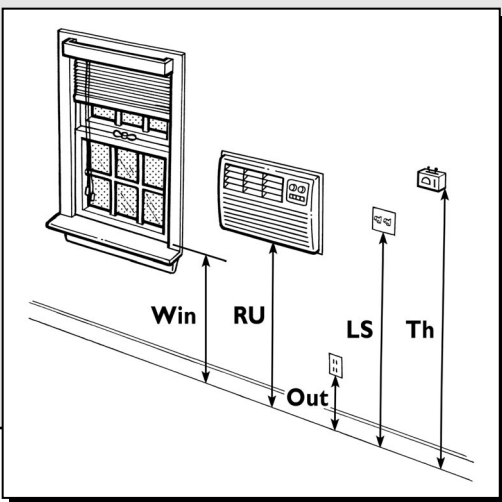

Light Switch	Outlet	Window	Room Unit	Thermostat
LS 1 _____	Out 1 _____	Win 1 _____	RU 1 _____	Th 1 _____
LS 2 _____	Out 2 _____	Win 2 _____	RU 2 _____	Th 2 _____
LS 3 _____	Out 3 _____	Win 3 _____	RU 3 _____	Th 3 _____
LS 4 _____	Out 4 _____	Win 4 _____	RU 4 _____	
LS 5 _____	Out 5 _____	Win 5 _____	RU 5 _____	

6.0

RECOMMENDATIONS

A Health Care Professional's Recommendations

In your professional opinion, what home modifications would you recommend and why?

Is there any additional information needed in order to match the person with the solutions?

B Health Care Services

List the services that you or others will be providing the client including functional mobility training, ordering mobility devices and/or durable medical equipment, and helping to get modifications implemented.
